

PDM module User Manual

1.0 Powering up the module

In order to switch on the module, simply plug in the AC adapter in the power supply connector. See *Table 1* for input DC Electrical requirements. After having applied the power, the module will switch on and, while all the internal diagnostic tests are performed, it will turn on the diagnostic output LEDs with green colour. After 20-25 seconds, if no error will occur, the LEDs will be switched off and the module will be ready for photon counting. If an error is encountered, all the internal voltages will be switched off and the diagnostic LEDs will display the problem using the colour code explained in *Table 2*. The module will remain in this situation until the power is removed.

Table 1. DC Input electrical characteristics

	<i>Min</i>	<i>Typ</i>	<i>Max</i>	<i>Unit</i>
<i>Input voltage</i>	5		12	Volt
<i>Input Power</i>			7	Watt

Note: input absolute maximum rating is 16V

Table 2. Diagnostic LED diagram

	TOP LED	BOTTOM LED
<i>Vin higher than 13V</i>	Red	Off
<i>Vin lower than 4.5V</i>	Orange	Off
<i>Wrong SPAD Bias Voltage</i>	Orange	Orange
<i>SPAD parameters memory fault</i>	Blinking Orange	Blinking Orange
<i>SPAD working temperature not reached or not stable</i>	Off	Orange
<i>Peltier current saturated</i>	Off	Red
<i>Normal Condition</i>	Green for 20-25 seconds after power-up, then Off	Green for 20-25 seconds after power-up, then Off

2.0 Inputs – Outputs

The module has one standard TTL output and one standard TTL gate input. Modules with the additional timing module installed have a second timing output.

TTL OUT

output: TTL OUT is designed to drive 50Ω coaxial cables and is internally series terminated as conceptually shown in *Figure 1*. This output is short circuit protected. The TTL output connector is a standard BNC. TTL OUT low level is 0V and TTL OUT high level when driving a 50Ω terminated input is about 3.5V.

Timing

output: NIM-standard fast-negative output. Typical NIM pulse amplitude is -800mV on a 50Ω terminated transmission line. In order to obtain the best performances, it is recommended to use the NIM timing output only with terminated 50Ω coax cables. NIM output connector is a LEMO 50Ω NIM-CAMAC series (ERN.00.250.CTL).

GATE IN

Input: Gate-in input is designed to accept a standard TTL signal, AC terminated. The impedance is 10kΩ in DC and 50Ω on the rising and falling edges of gate signal. Gate-in input must be considered a high impedance input and not a 50Ω terminated input. In *Figure 2* is shown the block diagram of the Gate-In input. Gate-in input has a standard BNC connector. *Gate is active low: disable counting=TTL low, enable counting=TTL high.*

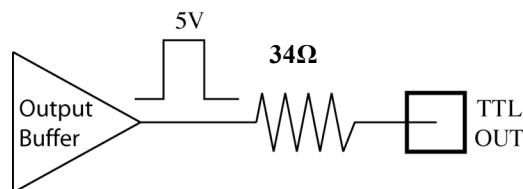

Figure 1: TTL OUT block diagram.

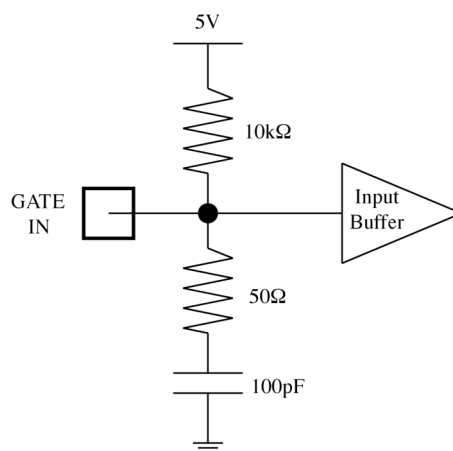

Figure 2 Gate-in Input block diagram

3.0 High count rate correction factor

It is well known that counting events with a detector that, after every detection, is blind for a fixed time, called dead-time ($T_{deadtime}$), causes an error in determining the true average counting rate. This happens because if n events are counted in a time window $T_{measure}$ long, the correct observing time is not $T_{measure}$ but $T_{measure}$ reduced by the total blind time. The total blind-time can be easily calculated by multiplying the n counted events with $T_{deadtime}$. The actual count rate of the observed phenomena (CR_{actual}) can thus be calculated from the measured count rate ($CR_{measured}$) as follows:

$$CR_{measured} = \frac{n}{T_{measure}} \quad (\text{Eq. 1})$$

$$CR_{actual} = \frac{n}{T_{measure} - n \cdot T_{dead-time}} = \frac{CR_{measured}}{1 - CR_{measured} \cdot T_{dead-time}} \quad (\text{Eq. 2})$$

Although the correction is straightforward the closer the $CR_{measured}$ is to the reciprocal of the dead-time, the higher is the correction and possibly the distortion to the measurement.

Dead-time correction can also be seen as a deviation from unity of the ratio between the actual incoming photon flux and the measured photon count rate. Given a dead-time, it is possible to calculate this ratio, called correction factor, as a function of the measured count rate (*Figure 3*).

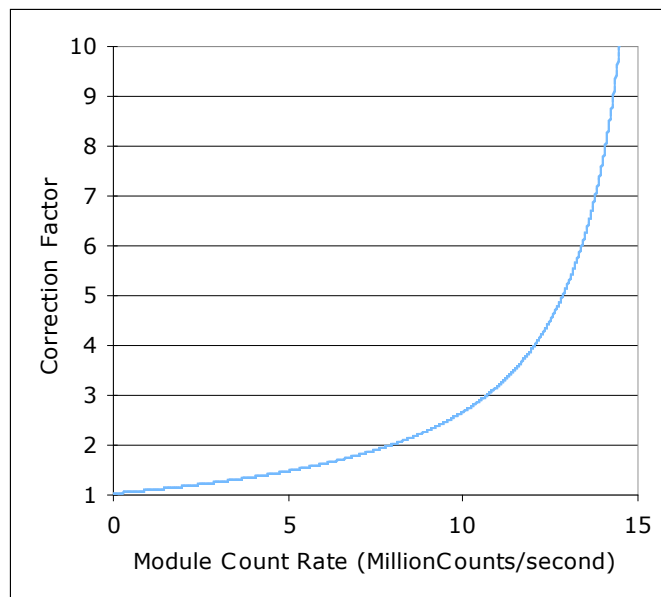

Figure 3. Calculated correction factor for a PDM module with 62ns dead-time.

4.0 Optical Interface

SPAD sensor is placed in the centre of the front panel $\pm 0.25\text{mm}$ in both x and y directions. SPAD sensor surface is placed $2.6\text{mm} \pm 0.4\text{mm}$ from the window cap top glass surface.

